

Product overview

Developed closely with local authorities, housing associations, occupational therapists and contractors, the Onyx Care Pod is an affordable, stylish yet functional showering solution to clearing any backlog of adaptations.

Features

- + Safe and accessible
- + Standalone Onyx shower cubicle with Larenco duo glass care screen and complete pack of necessary care accessories, providing an aesthetic yet long lasting adaptation solution for a vast range of needs
- + A truly aesthetic solution to disabled adaptations
- + Quick and easy installation
- + Alcove and corner configurations available
- + Onyx shower tray – Easy access, low level (26mm), slip resistant treatment rating C, with textured slate effect
- + 6mm toughened glass with 'Stay Clear' coating
- + AKW Duolinx magnetic locking handle
- + Constructed using water and scratch resistant, structural grade wall panels/boards
- + Polished anodised aluminium external profiles
- + 400mm filler panel included
- + Gravity and pumped waste options available
- + Choice of BEAB Care approved electric and TMV3 mixer shower options
- + High flexibility when installing accessories

Product Specification

- + **Height:** 2m
- + **Lengths:** 1200mm, 1400mm, 1600mm, 1700mm
- + **Widths:** 800mm, 900mm



Guarantee & Approvals



The Onyx Care Pod and all AKW shower trays, AKW shower screens and AKW shower seats come with a lifetime warranty against manufacturing defects*.

*The lifetime warranty excludes normal wear and tear in general domestic applications. It applies only to products being installed for the first time and according to relevant local and national regulations.



As standard

AKW SmartCare Plus Electric Shower comes with a 5 year warranty as standard with extended warranties available*.

*Please note that the product must be registered within 30 days with AKW Medi-Care Limited to activate your guarantee.



AKW electrical items come with a 5-year warranty against manufacturing defects*.

Other branded electrical products carry the warranty of the manufacturer. *Excluding extractor fans which carry 3 year warranty.



As standard

AKW Arka® Thermostatic Mixer Shower comes with a 3 year warranty as standard with extended warranties available*.

Please refer to our terms and conditions in the AKW catalogue for further information. *2 year extended warranty option available.



100% waterproof
Exclusions apply to door area.

OT benefits

- + The Onyx Care Pod includes the Onyx shower tray, which at only 26mm has the shallowest threshold of all our trays.
- + Onyx shower tray boasts a higher slip-resistance rating than other surface mounted trays, with a textured slate finish which is kinder on the feet than raised dimples.
- + Reduced contact time between contractors and occupants, therefore reducing potential exposure to Covid-19.
- + High-quality, AKW Larenco 6mm toughened glass is included for added user safety. We have been supplying this product for a number of years with very positive feedback. Due to the increased cost, glass screens have predominantly been used for self-funded adaptations. The Onyx Care Pod reduces the costs incurred during installation time, meaning this higher level product can be offered at a similar or cheaper cost when compared with a conventional adaptation.
- + Structural wall panels/boards are constructed of flexible structural grade materials which allows shower units, as well as mobility aids such as shower seats and grab rails, to be fixed directly, at a user specific height, either during or post installation.
- + Wall panels are far more hygienic, lower maintenance, longer lasting and more durable than tiling, with no need for grout which can harbour bacteria and requires tough cleaning. Wall panels are a great solution for clients with smearing tendencies.
- + Great solution for claustrophobic users, with the option of having glass at the front and side, offering a more open environment.
- + The Onyx shower tray can be recessed to provide level entry or alternatively a ramp can be supplied.
- + Onyx Care Pod comes with a lifetime guarantee and boasts care features which ensures the longevity of the installation. The recessed Onyx shower tray provides level access and the duo doors allow carer-assisted bathing, providing a long-term solution which considers the user's future requirements.
- + AKW's unique Duolinx system is easy to use, with a magnetic locking handle that connects the top and bottom shower door sections, allowing the user to open and close one or both screens, giving maximum flexibility for a range of showering needs.
- + The mid-grey grab rails from our dementia-friendly retirement and care range, are an excellent option for the visually impaired. The grab rails achieve the required LRV contrast against the white wall panels. Furthermore, they are a more stylish solution than the traditional blue seen in many adaptations such as the product comparison found on pages 4-5.
- + Vastly reduced installation time – maximum of two days compared to a traditional 5-7 day adaptation – which decreases labour, time and cost requirements, as well as contact with and inconvenience for residents. This also reduces the need for and costs of respite care whilst the works take place.

Specifier and contractor benefits

- + Vastly reduced installation time – maximum of two days to remove the existing bathroom and install the Onyx Care Pod, when compared with the traditional 5-7 day adaptation installation – which decreases labour, time and costs, as well as contact with, and inconvenience for residents.
- + Reduced installation time also means the same team of installers could complete 2-3 installations a week. This would help to clear any backlogs, allow quicker spend of DFG budgets and should be more profitable for the installer.
- + When factoring in the initial material costs against labour and time savings, we expect the total cost of supply and fit should be in line with a standard adaptation while using much higher end products.
- + Less preparation is required, e.g. no need to strip, prepare and tile existing walls. Any patching work needed will be minimal compared to completing a full adaptation.
- + Less decorative work is also required, as ceilings etc. are far less likely to have been damaged during the removal stage.
- + Fewer materials are required on site and all supplies, including timber and plumbing fittings, can be sent in one contact-free delivery from AKW.
- + Compatible with gravity and pumped waste options offering greater installation flexibility. Pumped waste option is 53mm below the shower tray level so should be within the screed for use with unbreachable floors.
- + Simplified costing for materials with the Onyx Care Pod pricing method and AKW One service offering.
- + Care Pod base structure comes attached to the Onyx shower tray, reducing installation time, leaving less room for error, and enabling a watertight finish.
- + No specialist floor coving is required, which would be typically used in a wet room adaptation. This allows the flooring to be potentially done in-house rather than subcontracted.
- + The simple and effective installation method reduces the chance of snagging and call backs to site.
- + The Onyx Care Pod is a very effective bath replacement solution (BOSI). However, providing it is ventilated sufficiently it can also be used as a standalone pod in any room of a house, providing a dignified solution to palliative care. To ensure a wipe clean, hygienic but attractive finish when used as a standalone pod, the structural wall boards have the same finish to both sides.

End user benefits

- + The Onyx Care Pod has been designed to be a highly functional care product as well as aesthetically pleasing.
- + High-quality, AKW Larenco 6mm toughened glass is included for added user safety.
- + Reduced contact time between contractors and occupants, therefore reducing potential exposure to Covid-19.
- + Shallow 26mm Onyx shower tray can be recessed to provide level-entry access for wheelchair users, alternatively a 20mm ramp can be supplied.
- + Carer-assisted bathing available with Larenco 6mm toughened glass duo door.
- + Much less work would be required and costs incurred if the room was returned to a bathroom in the future.
- + Great solution for claustrophobic clients as glass at the front and side offers a more open environment.
- + Easy to clean with warm soapy water.

Dimensions

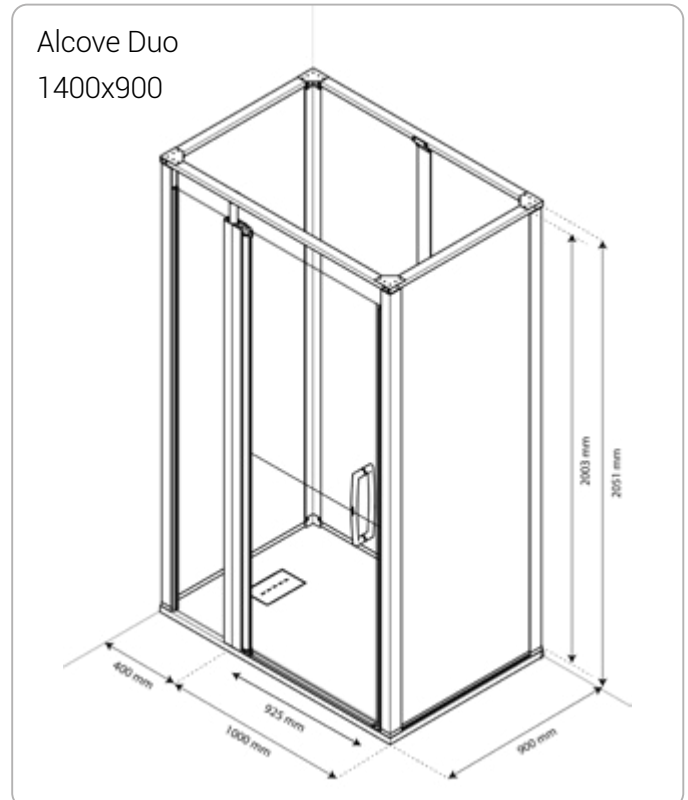
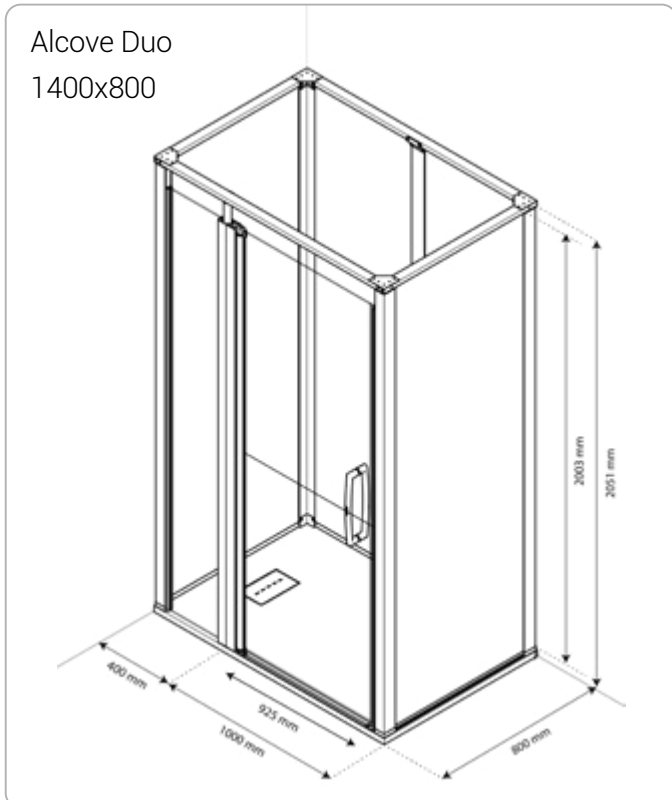
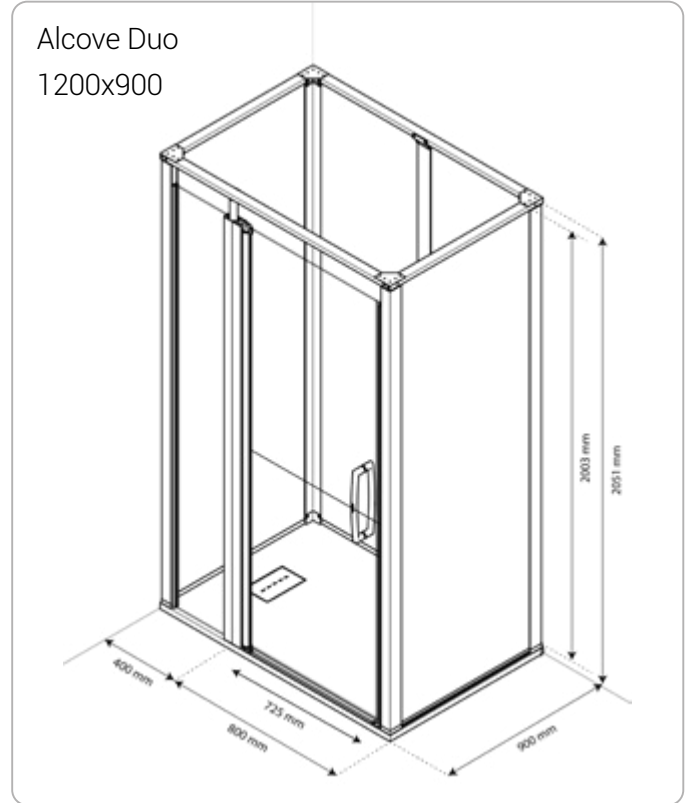
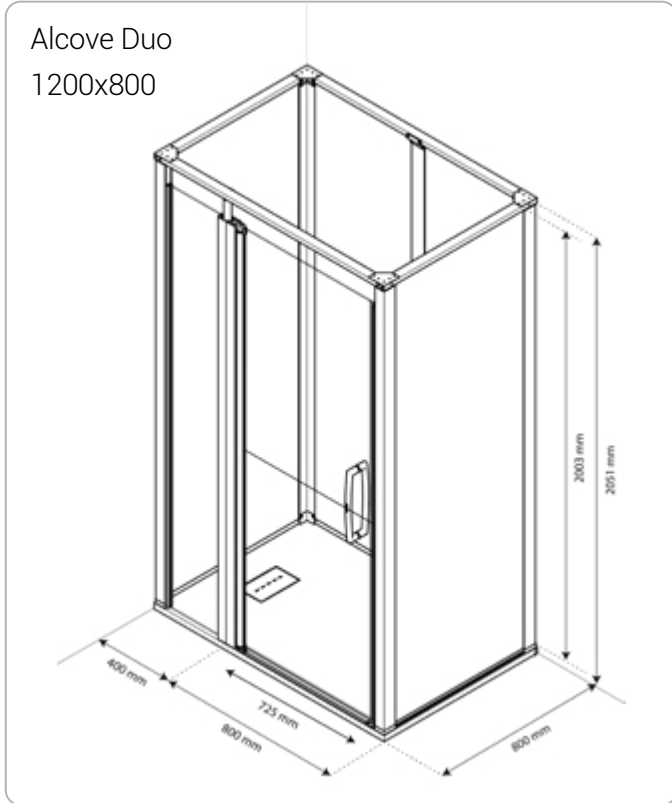

Dimensions

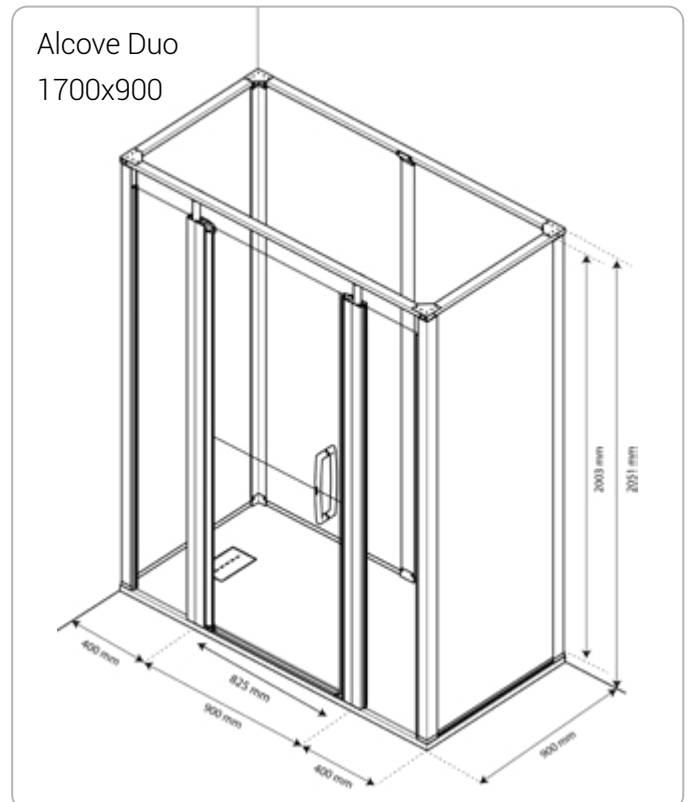
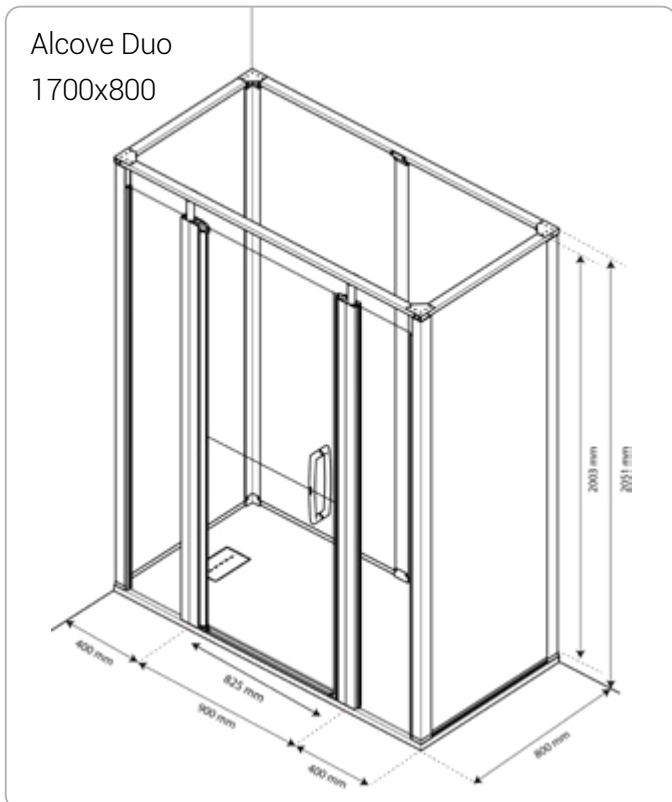
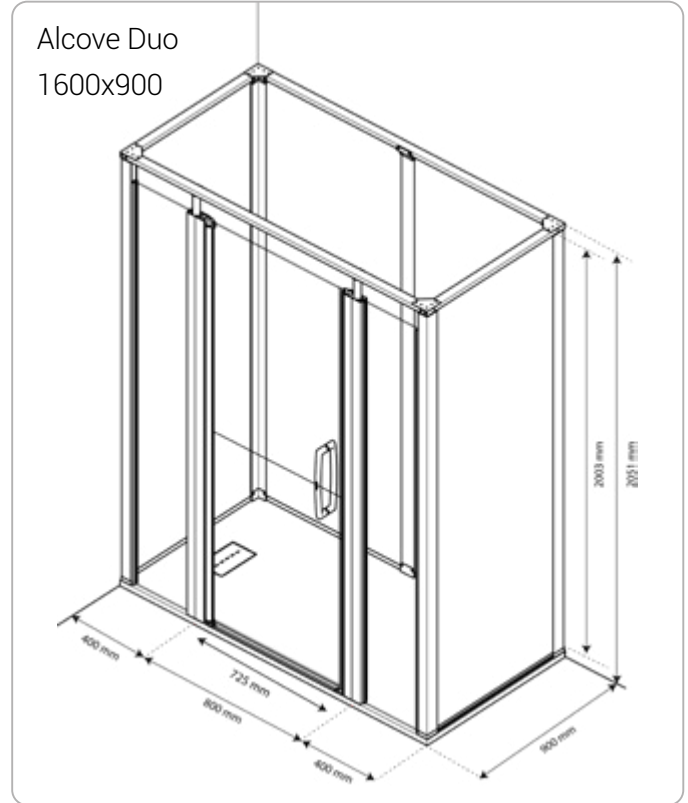
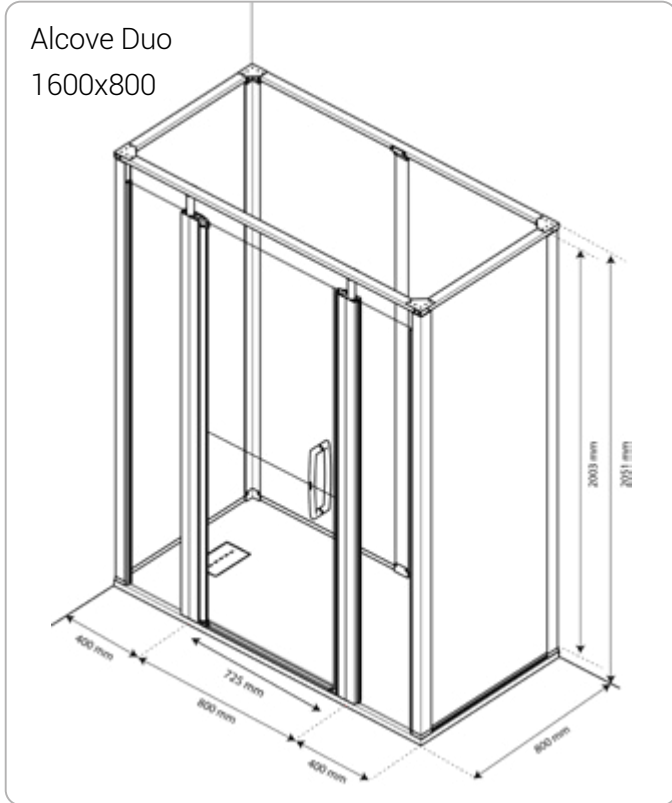

Dimensions

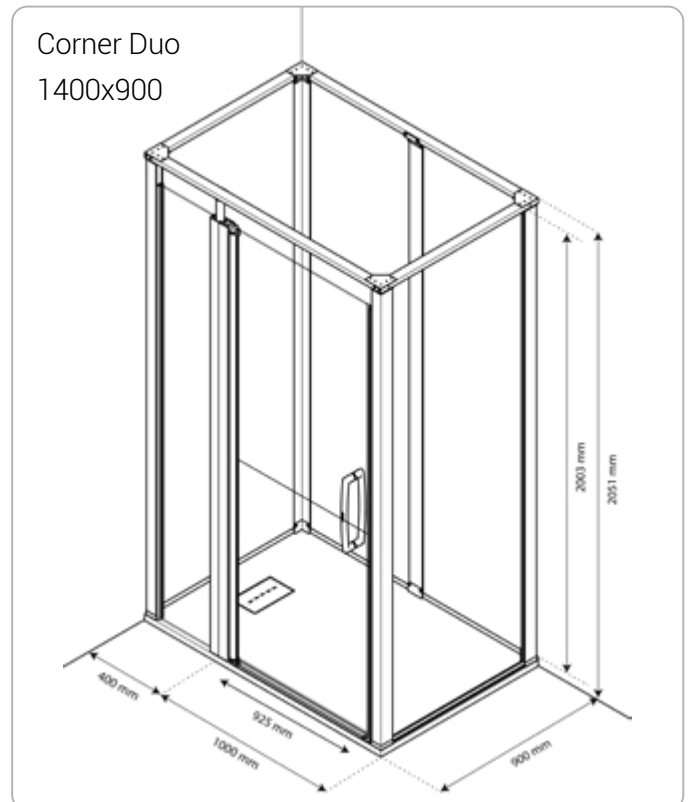
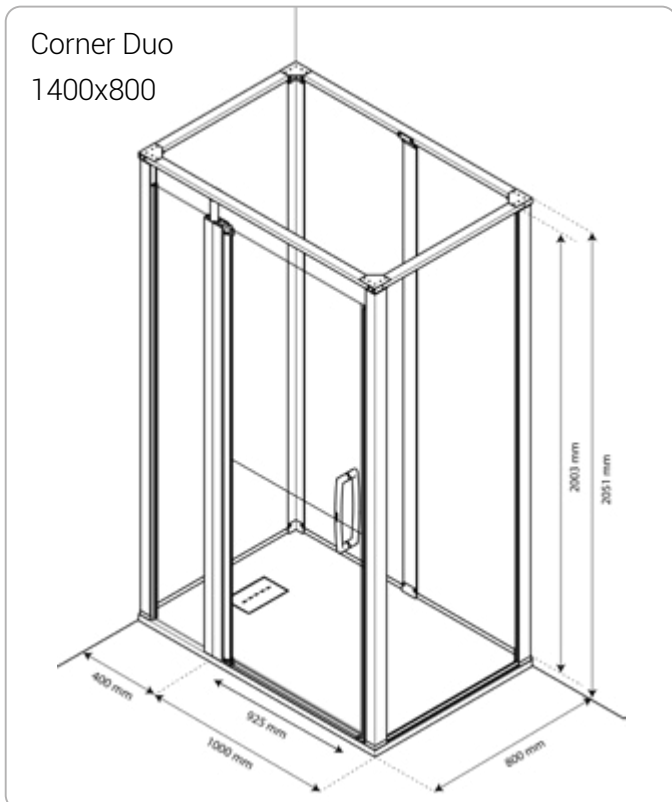
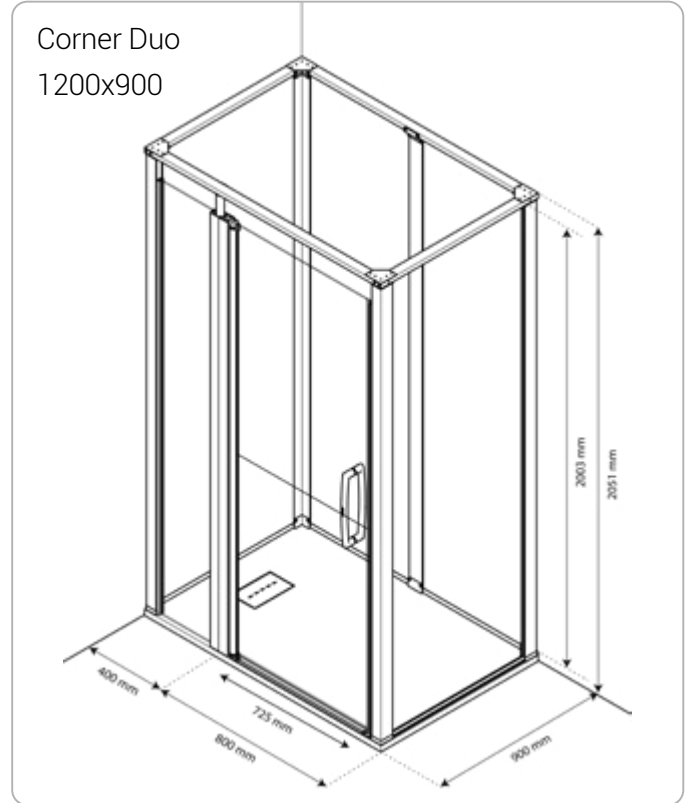
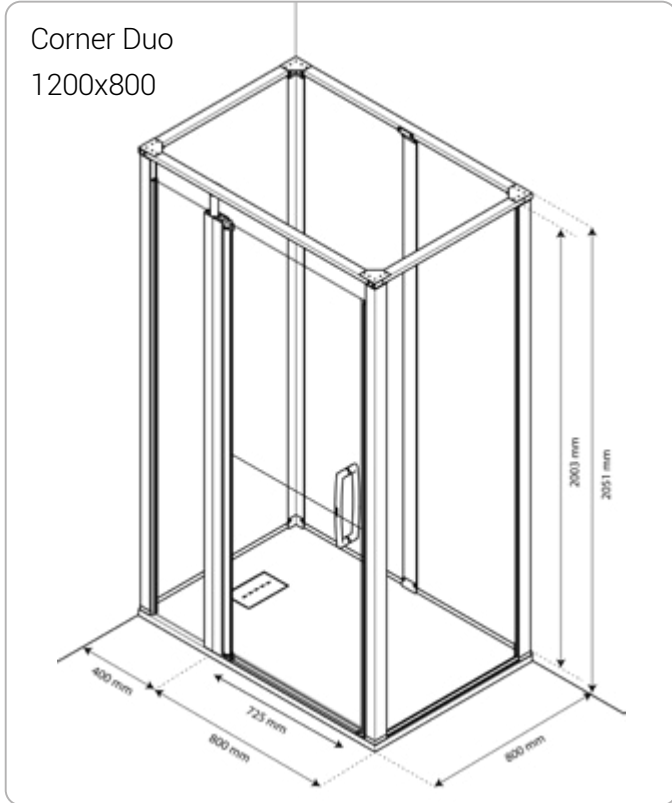

Dimensions

