

Accessible Kitchens



MADE FOR YOU

The heart of every home is the kitchen

Our kitchens say a lot about us; our style, our needs, our family, our friends, how we like to live.

At AKW we make award-winning kitchens that our customers love. Each kitchen is specifically designed to your abilities, available space and personal taste.

No other manufacturer offers the same range of special accessories and incredible features, because no one else incorporates inclusive design at every stage of the process. From the type of unit to the layout of the room, AKW creates accessible kitchens which support your independent living, look amazing and work brilliantly.

That's why AKW is so widely recommended by occupational therapists, local authorities, housing associations... and our customers.

AKW[®]
Life Made Better



Independence Kitchen with
Ivory Gloss Saponetta doors



Form and function
in perfect harmony





AKW
Life Made Better

The AKW Difference	6
ActivMotion®	10
Independence Kitchen	12
Liberty Kitchen	18
Options: Handles	22
Options: Worktops	23
Features	24
Appliances	25



Our **specialist surveyors** are the most experienced in the UK and work closely with OTs, carers, architects and housing associations to create the most functional products on the market. As well as the layout of your room, they factor in accessibility,

functionality and your abilities. A **unique checklist of 150 questions**, detailed measurements (more than any other manufacturer) and time spent with you, and your carer or OT, creates a kitchen that's **expertly tailored to you** and your family and a pleasure to use every day.

THE AKW DIFFERENCE

Expertise you can trust

At AKW we focus exclusively on making fully accessible kitchens and bathroom products. That's all we do, and it's why we're so good at it.



Our surveyors provide a highly detailed set of drawings for you and your OT, specifying every measurement down to the smallest detail, along with 3D visualisations of what your kitchen will look like.

This ensures that your installer knows exactly where and at what height to install each item. No other manufacturer provides the detailed drawings we do, because no one else designs specialist fully accessible kitchens fitted exactly to your physical abilities and requirements.

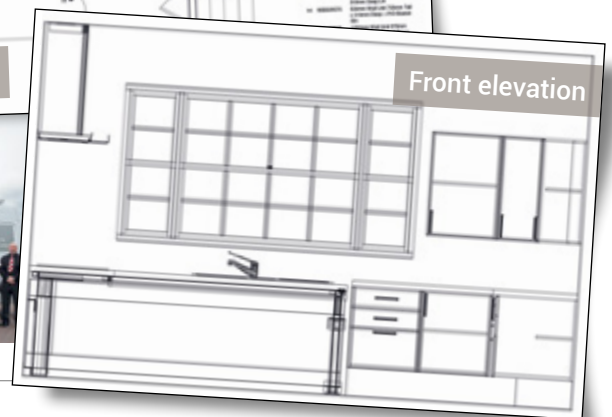
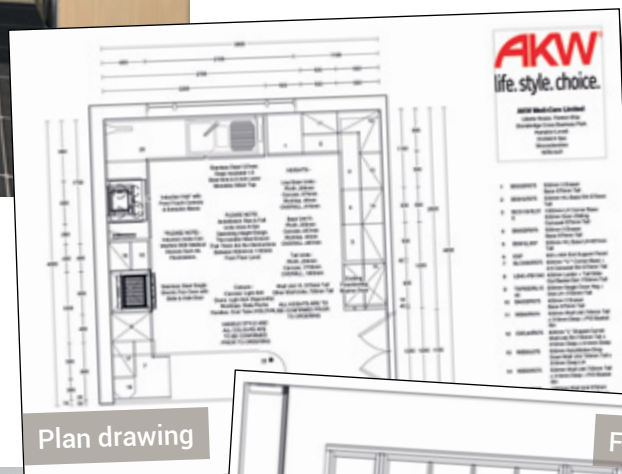

Our simple three stage survey process:

1

Within 10 working days of your call an AKW surveyor undertakes a site survey.

2

The design combines healthcare professional reports and your specific needs.

3

Within 5 working days, we'll provide a 2D plan and 3D visual of how your new kitchen will look.

THE AKW DIFFERENCE

Unique features you'll love

It's the small things that make a difference, but with an AKW accessible kitchen every detail, both big and small, has been carefully considered with you in mind.

Here we show you just some of the incredible features that make our kitchens both unique and a pleasure for users of all abilities.



Pull-Out Heat Drawer at exactly the right height for easy and safe side transfer from the oven.



Pull-Down Baskets glide effortlessly, putting cupboard contents easily within reach.



ActivMotion® Wall Units descend at the push of a button so you don't have to stretch or strain.



Larder Units with Slide-Out or Swing-Out baskets give easy access from both sides.



L-Shape Rise and Fall Units support hobs, sinks and up to 3 metre worktop lengths. Activated at the push of a button, it is the ultimate and easiest way to adjust the worktop height to suit everyone.



Extra Tall Deep Recessed Plinths allows wheelchair foot-plates to fit underneath.



Wall Units are set lower than normal above the worktop so you can reach up more easily.



Ovens are set at a lower height, enabling safe and easy transfer of hot dishes onto the side.



Corner Units feature easy-glide pull-out mechanisms, maximising storage and access.



Adjustable Legs mean units and worktops are tailored to the perfect height for you.



Fixed Worktops are also set at the correct height and combine well with Rise and Fall Units.



Single Doors on tall units are easier to open and simpler to manage for wheelchair users.



A handy **Pull-Out Ironing Board** tucks neatly away in a drawer when not needed to save space.



Extra Wide Hinges allow doors to open much wider than normal for better, easier access.



High-Sided Drawers give extra stability, strength and ensure nothing falls out of the side.



Shallow Sinks let wheelchair users get much closer and are heat-insulated to protect legs.

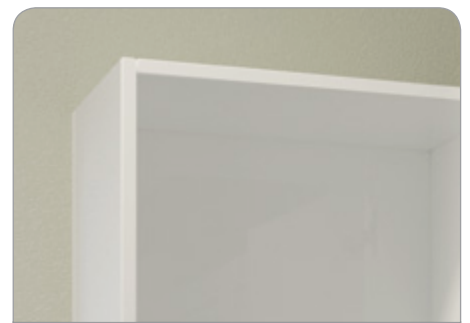

18mm Carcasses are at the heart of a much stronger, longer-lasting kitchen.

Rise and Fall Units for ultimate comfort

The ActivMotion® Rise and Fall range from AKW is at the centre of most inclusive kitchens, whether it's an adaptation or a fully accessible kitchen.

The conveniently placed controls allow you to adjust worktops to exactly the right height for you, and the shelves of your wall units can magically descend to within reach at the simple push of a button.

ActivMotion® Worktops come in a wide range of configurations and sizes to suit every user and every room. They can also be used to support sinks and hobs, making them ideal for wheelchair users (giving easy access underneath) and multi user areas.



The units can support sinks or hobs. Users can get much closer for safety and comfort.



The convenient **push button control** allows you to adjust the height of the unit to suit.



A touch-sensitive safety strip on the underside of the unit **shuts off power on contact.**

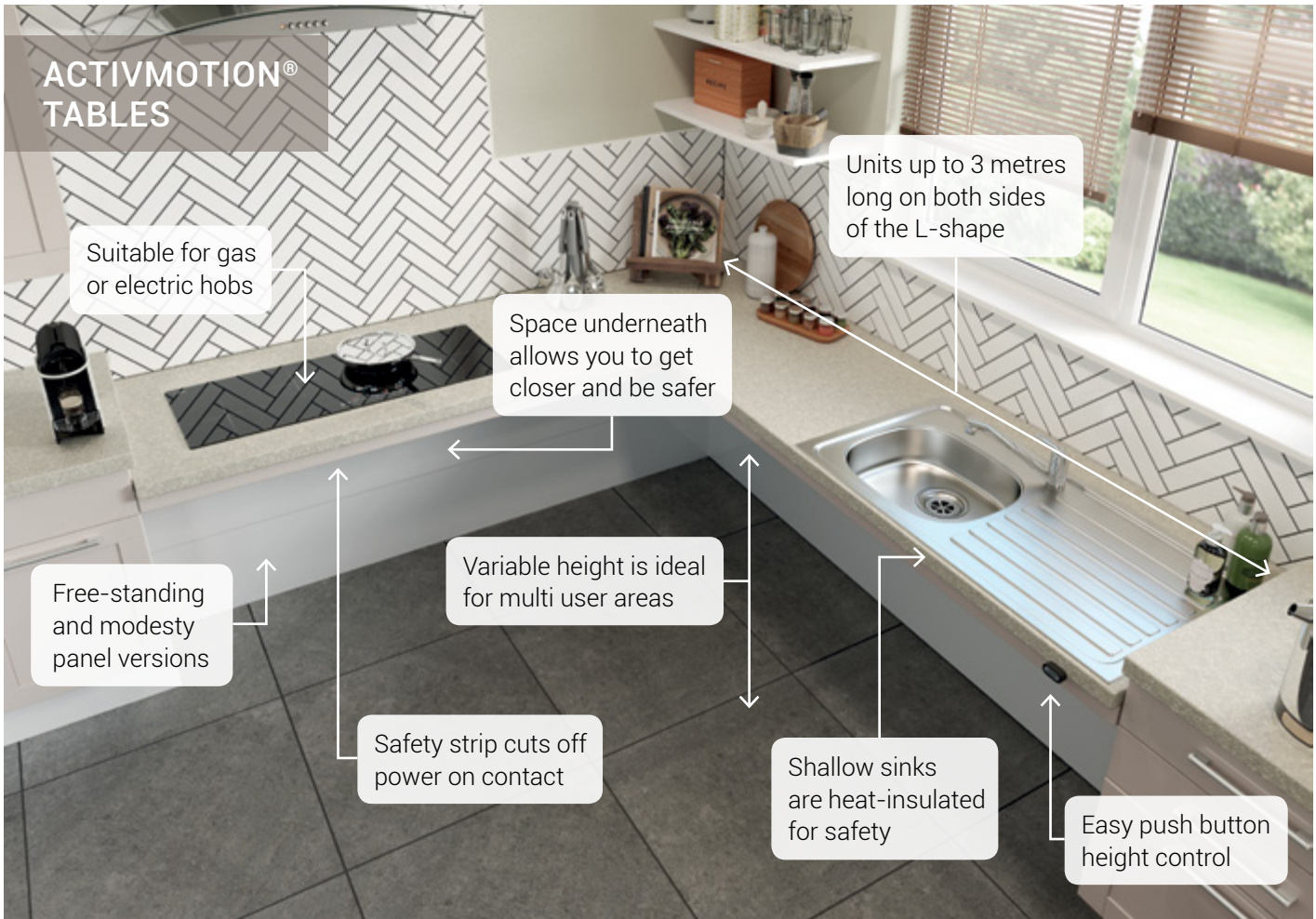

INDEPENDENCE



Designs tailored for you

An Independence Kitchen is made to measure for your individual needs. An enhanced range of colours, doors and worktops, along with colour matched fascias, carcasses and other bespoke options, puts you in control of your ideal kitchen.



INDEPENDENCE KITCHEN

Unit Options

Tall units:

Larder/Broom Unit

1700mm high*

	Left	Right
300mm wide	LB30L	LB30R
400mm wide	LB40L	LB40R
500mm wide	LB50L	LB50R
600mm wide	LB60L	LB60R

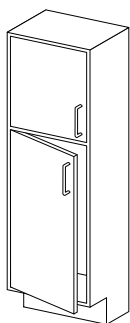

Larder Unit (3 Drawers)

1700mm high*

	Left	Right
300mm wide	LAR30L	LAR30R
400mm wide	LAR40L	LAR40R
500mm wide	LAR50L	LAR50R
600mm wide	LAR60L	LAR60R

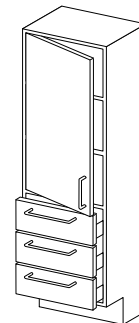

Larder Unit (with Full Height Basket Set)

1700mm high*

Slide-Out Baskets:

300mm wide	LB30+FB
400mm wide	LB40+FB

Swing-Out Baskets:

500mm wide	LB50+FB
600mm wide	LB60+FB

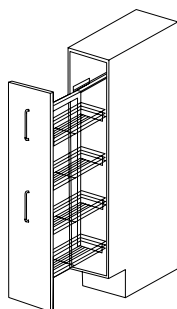

Tall Single Oven Housing Unit

1700mm high*

600mm wide (left)	TAP60DRL
600mm wide (right)	TAP60DRR

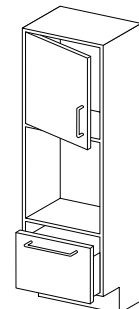

Tall Single Oven & Microwave Housing Unit

1700mm high*

600mm wide (left)	TAP60SOL+M
600mm wide (right)	TAP60SOR+M

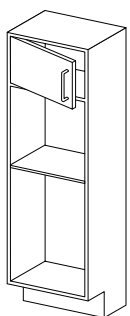

Tall Double Oven Housing Unit

1700mm high*

600mm wide (left)	TAP60DDRL
600mm wide (right)	TAP60DDRR

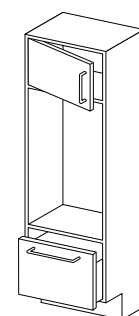

Tall Fridge/Freezer Housing Unit

1700mm high*

600mm wide (left)	FF60L
600mm wide (right)	FF60R

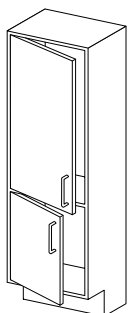

Larder/Fridge Unit (1 drawer)

1700mm high*

600mm wide (left)	FR60DRL
600mm wide (right)	FR60DRR

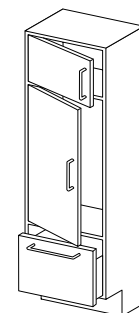

*Tall unit heights variable as Independence range is made to measure.

Wall units:

Open Wall Unit
735mm high

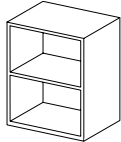

500mm wide	OS50
600mm wide	OS60

Wall Unit (Single Door)
735mm high



	Left	Right
300mm wide	W30L	W30R
400mm wide	W40L	W40R
450mm wide	W45L	W45R
500mm wide	W50L	W50R
600mm wide	W60L	W60R

Wall Unit (Double Door)
735mm high

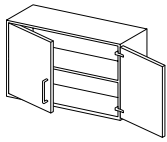

500mm wide	WD50
600mm wide	WD60
700mm wide	WD70
800mm wide	WD80
900mm wide	WD90
1000mm wide	WD100
1100mm wide	WD110
1200mm wide	WD120

Wall Unit (Single Door with Pull-Down Baskets)
735mm high

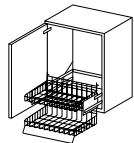

	Left	Right
400mm wide	WB40L	WB40R
500mm wide	WB50L	WB50R
600mm wide	WB60L	WB60R
400mm wide	WBVL40	WBVR40
500mm wide	WBVL50	WBVR50
600mm wide	WBVL60	WBVR60

Wall Unit (Double Door with Pull-Down Baskets)
735mm high

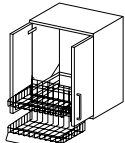

500mm wide	WDB50
600mm wide	WDB60
500mm wide	WDBVL50
600mm wide	WDBVL60

Wall Unit (Top Box)
290mm high

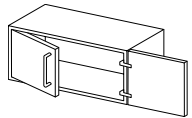

500mm wide	W50TB
600mm wide	W60TB
800mm wide	W80TB
1000mm wide	W100TB

Open End Wall Unit
735mm high

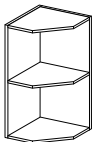

300mm wide	OEWS30
------------	---------------

Open Corner Wall Unit
735mm high

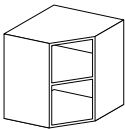

500mm wide	OCW50
600mm wide	OCW60

Corner Wall Unit (Double Door)
735mm high

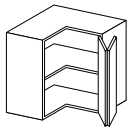

	Left	Right
500mm wide	CWL50L	CWL50R
600mm wide	CWL60L	CWL60R

Wall Unit (Four Door)
735mm high

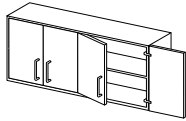

800mm wide	WDD80
900mm wide	WDD90
1000mm wide	WDD100
1100mm wide	WDD110
1200mm wide	WDD120

Base units:

Base Unit (2 Drawers)
575mm high



300mm wide	B302DR
400mm wide	B402DR
450mm wide	B452DR
500mm wide	B502DR
600mm wide	B602DR
800mm wide	B802DR
1000mm wide	B1002DR

Base Unit (3 Drawers)
575mm high



300mm wide	B303DR
400mm wide	B403DR
450mm wide	B453DR
500mm wide	B503DR
600mm wide	B603DR
800mm wide	B803DR

Highline Base Unit (Single Door)
575mm high

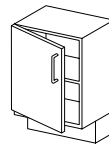

	Left	Right
300mm wide	B30HLL	B30HLR
400mm wide	B40HLL	B40HLR
450mm wide	B45HLL	B45HLR
500mm wide	B50HLL	B50HLR
600mm wide	B60HLL	B60HLR

PLANNING TIP: We recommend pull-out baskets for disabled use with these units.

Highline Base Unit (Double Door)
575mm high

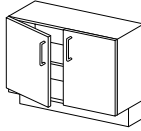

800mm wide	B80HL
1000mm wide	B100HL
1100mm wide	B110HL
1200mm wide	B120HL

PLANNING TIP: We recommend pull-out baskets for disabled use with these units.

Highline Base Unit (Single Door with 2 Baskets*)
575mm high

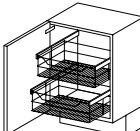

	Left	Right
400mm wide	B40BAL	B40BAR
450mm wide	B45BAL	B45BAR
500mm wide	B50BAL	B50BAR
600mm wide	B60BAL	B60BAR

*Includes baskets, fixing brackets and runners.

Highline Base Unit (Double Door with 4 Baskets*)
575mm high

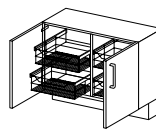

800mm wide	B80BA
1000mm wide	B100BA
1200mm wide	B120BA

*Includes baskets, fixing brackets and runners.

Base Unit (3 Drawers with Pull-Out Table*)
575mm high

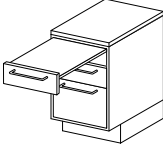

500mm wide	B503DR+POT
600mm wide	B603DR+POT

*Pull-out table extends to 800mm.

Base Unit (3 Drawers with Pull-Out Ironing Board*)
575mm high

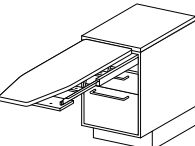

400mm wide	B403DR+PIB
450mm wide	B453DR+PIB
500mm wide	B503DR+PIB

*Pull-out ironing board extends to 950mm.

Base Unit (3 Drawers with Pull-Out Heat Drawer & Worktop Saver)
575mm high

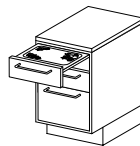

400mm wide	B403DR+HD
450mm wide	B453DR+HD
500mm wide	B503DR+HD
600mm wide	B603DR+HD

Open End Base Unit
575mm high

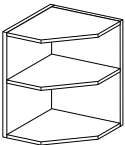

300 x 560mm wide	OEBL/R
------------------	---------------

Bridging units:

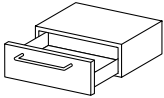

Under Worktop Bridging Unit

300mm wide	BR130
400mm wide	BR140
450mm wide	BR145
500mm wide	BR150
600mm wide	BR160

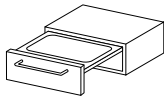

Under Worktop Pull-Out Heat Drawer & Chopping Board

400mm wide	BR140+HD
450mm wide	BR145+HD
500mm wide	BR150+HD
600mm wide	BR160+HD
650mm wide	BR165+HD

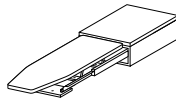

Under Worktop Bridging Unit Pull-Out Ironing Board

400mm wide	BR140+PIB
450mm wide	BR145+PIB
500mm wide	BR150+PIB

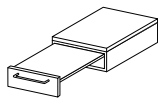

Under Worktop Bridging Unit Pull-Out Table

500mm wide	BR150+POT
600mm wide	BR160+POT

Trolley units:

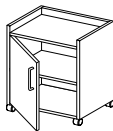

Trolley Unit (Single Door)
622mm high

	Left	Right
500mm wide	T50HLL	T50HLR
600mm wide	T60HLL	T60HLR

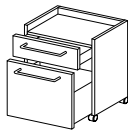

Trolley Unit (Double Drawer)
622mm high

500mm wide	T502DR
600mm wide	T602DR

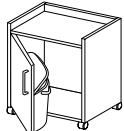

Trolley Unit (with Waste Bin)
622mm high

	Left	Right
500mm wide	T50WBL	T50WBR
600mm wide	T60WBL	T60WBR

Corner Carousel units:

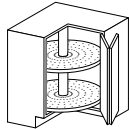

Corner 3/4 Carousel Unit
575mm high

	Left	Right
800mm wide	BLCH80L	BLCH80R
900mm wide	BLCH90L	BLCH90R

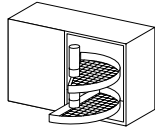

Corner Semi Circle Carousel Unit
575mm high

1000m wide	Left	Right
w/ 400mm door	BCH100/4L	BCH100/4R
w/ 500mm door	BCH100/5L	BCH100/5R

Diagram of corner unit shown is left hand blank.

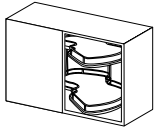

Corner Slide-Out Carousel Unit
575mm high

1000m wide	
w/ 500mm door (LH)	BCS100/5L
w/ 500mm door (RH)	BCS100/5R

Diagram depicts carousel for a LHB corner unit. Only available for corner units with a door of 500mm or greater.

Independence Door & Cabinet Colour Options:

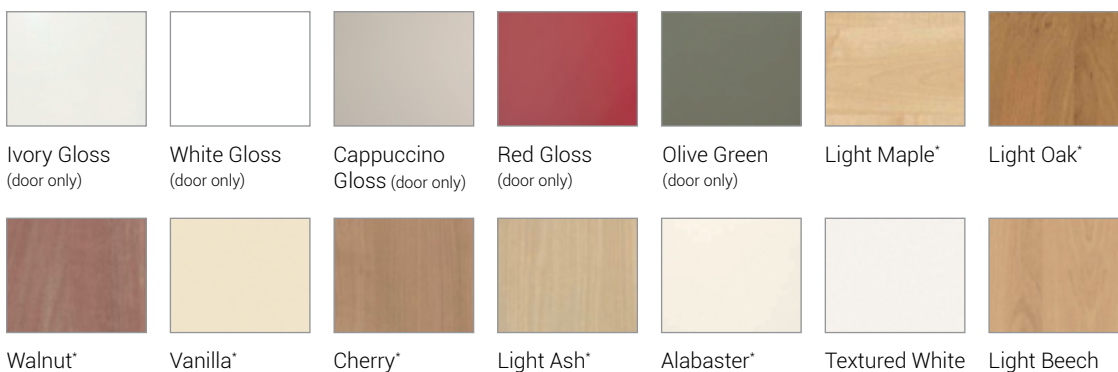

The colours in this brochure are for reference only and the item should be seen prior to purchase.

*2mm edged (non-gloss), Saponetta or Shaker profiles available.

LIBERTY





Reflect your style

The Liberty Kitchen range is easy to assemble, so your dream kitchen can become a reality in no time. Simple, affordable and with a range of worktop, door, accessory and appliance options, now you can easily have the kitchen you've always wanted.

LIBERTY KITCHEN

Unit Options

Tall units:

Tall Single Oven Housing Unit
1719mm high

600mm wide (with drawers) **LIBAHDRLR**
600mm wide (with door) **LIBAHFLR**

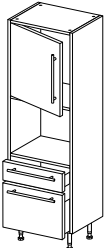

Tall Larder/Broom Unit
1719mm high

300mm* wide **LIBLB36LR**
500mm* wide **LIBLB56LR**
600mm* wide **LIBLB66LR**

*Pull-out baskets can be supplied for these items (optional extra).

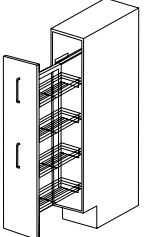

Wall units:

Wall Unit (Single Door)
735mm high

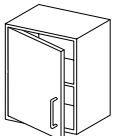

300mm wide **LIB533WLR**
400mm* wide **LIB543WLR**
500mm* wide **LIB553WLR**

*Pull-down baskets can be supplied for these items (optional extra).

Wall Unit (Double Door)
735mm high

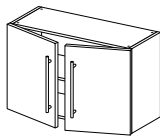

600mm* wide **LIB563W2D**
1000mm wide **LIB5103W2D**

*Pull-down baskets can be supplied for this item (optional extra).

Corner Wall Unit (Double Door)
735mm high

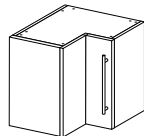

625 x 625mm wide **LIB633CWLR**

Base units:

Base Unit (3 Drawers)
588mm high



300mm wide **LIB536DR3**
500mm* wide **LIB556DR3**

*Heat drawer, pull-out ironing board and pull-out table available at extra cost.

Highline Base Unit (Single Door)
588mm high

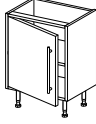

300mm wide **LIB536FLR**
400mm* wide **LIB546FLR**
500mm* wide **LIB556FLR**
600mm* wide **LIB566FLR**

*PLANNING TIP: Pull-out baskets are recommended with these units (optional extra).

Corner Base Unit (Double Door)
588mm high

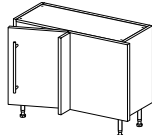

1000mm wide with 500mm door,
625mm blank (1125mm O/A) **LIB5106C5LR**

Diagram shown is right-hand blank.
Carousels are available for this item (optional extra).

Base Unit (2 Drawers)
588mm high



600mm wide **LIB566DR2**

Base Unit (Double Door)
588mm high

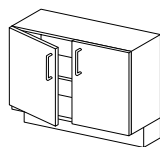

1000mm wide **LIB5106LR**

LIBERTY KITCHEN

Accessories

Accessories:

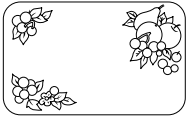

Worktop Saver

Heatproof cutting surface
WTS

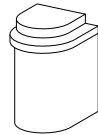

Waste Bin

PVC self-opening Waste Bin
WB

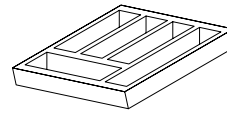

Cutlery Tray

300mm wide	CT3
400mm wide	CT4
500mm wide	CT5
600mm wide	CT6

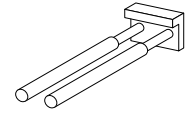

Towel Rails

Telescopic Towel Rails
TTR

Panels & Plinths:

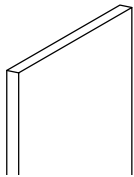

Worktop Support Panel

Beech	KNBEWS
Maple	LMPEWS
Oak	KNOEWS
White	LGLEWS

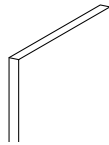

Decor End Panel (Wall Units)

Beech	LNBDWPM
Maple	LMPDWPM
Oak	LNODWPM
White	LGLDWPM

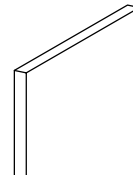

Custom Fit Panels

Beech	LNBZCFP
Maple	LMPCFP
Oak	LNOCFP
White	LGLCFP

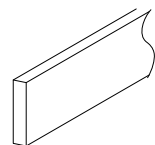

Plinth (2500 x 300mm)

Beech	LNBIKCP25
Maple	LMPIKCP25
Oak	LN0IKCP25
White	LGWIKCP25

Fixtures:

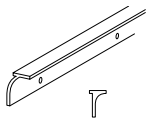

Jointing Strip Corner Pattern

Corner Jointing Strip **MJS**

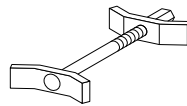

Worktop Bolts

Pair **WTBT**

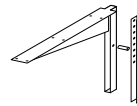

Heavy Duty Worktop Brackets

Bracket **HDWTBK**

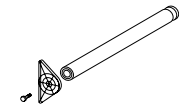

Supporting Leg (Adjustable Height)

60mm dia. Chrome **LEG**

Liberty Door & Cabinet Colour Options:



White

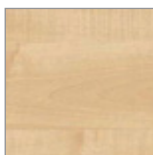

Light Maple

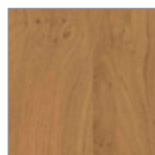

Light Oak

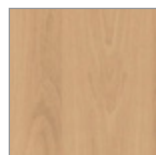

Light Beech

The colours in this brochure are for reference only and the item should be seen prior to purchase.

KITCHEN OPTIONS

Door Handles



Satin Nickel Bow

128mm centres
160mm centres



D Handle

128mm centres
160mm centres



Chrome Flat D Handle

160mm centres



Bar Handle Square Ends

128mm centres
160mm centres



Chrome D Handle

128mm centres
160mm centres



Splayed Oval Tube Handle

160mm centres



Aries Bar Handle

128mm centres
160mm centres

KITCHEN OPTIONS

Worktops



* Breakfast bars are supplied as a standard worktop. The length and corners can be customised on site by your installer.

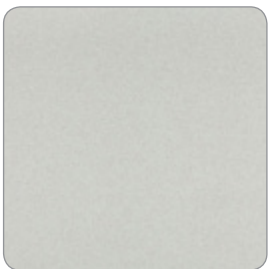

Luna Beige



Aticos Gold Surf



Kota Surf



Slate Surf



Maryland Fonce Surf



Midnight



Butcher Block Medium



Ebony Stripwood



Antique Block Walnut



Aztec Granite

KITCHEN OPTIONS

Even more great features

Innovative features designed to make your life easier and your kitchen a safer, more accessible and more enjoyable environment for everyone.



Tall Plinths and Adjustable Legs

Some manufacturers will hang their base units, claiming that makes the kitchen accessible.

We use adjustable legs with tall and extra deep plinths. This ensures the correct height and that dirt can't easily collect underneath, where it's difficult to reach.



Breakfast Bar

- + Breakfast Bars are adjusted to the correct height for the primary user
- + They provide a comfortable and stylish area at which to work, eat and chat
- + Supplied as a standard worktop. Length and corners can be customised on site by installer.



Electric Hobs

- + Ceramic and Induction hobs provide valuable extra worktop space when not in use
- + All come with front controls for easier access, so you don't have to reach over hot surfaces



Tailored Worktop Heights

Our surveyors identify exactly the right worktop height for you.

Standard worktops are positioned to accommodate appliances, but AKW can 'step' your worktop height according to your requirements.



Drawers not Doors

- + We recommend drawers in base units rather than cupboard doors
- + Drawers are easier to open and manoeuvre around than doors, giving easier access to the contents
- + All our Independence units feature soft close doors and drawers



Raised Base Units

- + The bottoms of our base units can be raised higher off the ground
- + This means less bending down for those with restricted mobility or in wheelchairs

KITCHEN OPTIONS

Appliances

**A range of appliances carefully selected for accessible kitchens.
Each one has inclusive features which make them easy and safe to use.**

Oven Features:

Ovens are one of the most important features in any kitchen and especially so in an accessible kitchen. Features such as side opening and Slide & Hide doors provide much safer access than conventional bottom-hinged doors. Optional anti-tip telescopic shelf kits provide extra safety and easy access. Setting the centre of the oven at the same height as the work surface makes transferring hot items much easier and large easy turn knobs help users with limited dexterity.



Beko Stainless Steel Single Oven

- + Upper and lower heating elements for even cooking
- + Telescopic rails included

Code: BEOVL/ BEOVR
(Left/Right hand hinged)



CDA Stainless Steel Single Oven (Reversible hinges)

- + Integrated anti-tilt shelves
- + Reversible side opening door
- + Touch control, programmable clock/timer

Code: LIBAPP096



Neff Stainless Steel Single Oven

- + Slide&Hide® fully retracting oven door
- + CircoTherm® heat system for even cooking on three levels
- + Self-cleaning catalytic coating

Code: LIBAPP030



Zanussi White Single Oven

- + Heat activated catalytic cleaning
- + Telescopic rails included
- + Fan cooled double glazed door

Code: ZOVSWL/ZOVSWR
(Left/Right hand hinged)



Zanussi Stainless Steel Single Oven

- + Heat activated catalytic cleaning
- + Telescopic rails included
- + Fan cooled double glazed door

Code: ZOVSXL/ZOVXSR
(Left/Right hand hinged)



Neff Telescopic Shelf Kit

- + Prevents shelves from dangerously over extending
- + Provides safe front and side access to heavy or hot dishes

Code: LIBAPP119

Kitchen options: Appliances

Hobs: (all available in 2 or 4 zone options)

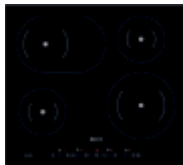

Induction

- + The safest and most inclusive type of hob
- + Heat is only activated when a magnetic pan is placed on top
- + No residual heat makes it suitable as a work surface
- + Front or touch controls

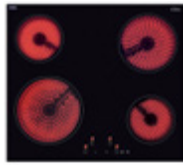

Ceramic

- + Residual heat warning indicator for safety
- + Front or touch controls as standard
- + Low profile surface ideal for limited dexterity
- + No specialist pans required



Electric

- + Front controls as standard
- + Space saving 'Domino' twin burner option
- + Superb budget option
- + Low profile surface provides easy access



Gas

- + Not recommended for accessible kitchens due to open flame and raised pan position
- + Front controls as standard for ease
- + Flame safe technology turns off gas if flame goes out

Extractor Hoods:



Beko Extractor

- + Variable 3-speed control
- + 1 x 40W Halogen light
- + Twin grease filters

Code: ZEXX



Zanussi Traditional White Extractor

- + Variable 3-speed control
- + Grease filter with saturation indicator

Code: ZEXW



CDA Stainless Steel Traditional Extractor

- + Push button control
- + Aluminium grease filter
- + 1 x 28W Halogen light

Code: LIBAPP006



CDA Stainless Steel Chimney Extractor

- + Ducted/Re-circulating
- + 2 x 50W Halogen lights
- + Twin fan motor

Code: LIBAPP010



CDA Curved Glass Extractor

- + Ducted/Re-circulating
- + Aluminium grease filters
- + 2 x 20W Halogen lights

Code: LIBAPP013

Sinks:



140mm Deep Reversible Monobloc Sink

- + Extra deep bowl
- + Can be installed with drainer on left or right to suit
- + Insulated version protects wheelchair users' legs from scalding

Code: EL860/EL860S (Insulated Bowl)



127mm Deep Monobloc Sink

- + Deep bowl
- + For use with single mixer tap
- + Insulated version available

Code: SD1271L/SD1271LS
(Left hand drainer/Insulated Bowl)
Code: SD1271R/SD1271RS
(Right hand drainer/Insulated Bowl)



127mm Deep 2TH (Pillar/Deck)

- + Deep bowl
- + For use with two taps
- + Insulated version available

Code: SD1272L/SD1272LS
(Left hand drainer/Insulated Bowl)
Code: SD1272R/SD1272RS
(Right hand drainer/Insulated Bowl)



150mm Deep Round Bowl

- + Shallow bowl design
- + Stylish round bowl can be inset into worktops

Code: RB



Round Drainer

- + Accompanies round bowl
- + Provides useful and stylish drainage surface

Code: RD

Taps:



3" Single Lever Monobloc Mixer Tap

Code: LEV13



9" Single Lever Monobloc Mixer Tap

Code: LEV19



3" Dual Lever Monobloc Mixer Tap

Code: LEV23



Pair High Neck Pillar Taps

Code: LEV03 (3" Lever)
LEV06 (6" Lever)

For a full list of appliances, please see price list.



AKW
Life Made Better

Orders & Quotes

01905 823 299
kitchens@akw-ltd.co.uk

General Enquiries

01905 823 298
sales@akw-ltd.co.uk

Technical Enquiries

01905 560 219
technicalenquiries@akw-ltd.co.uk

AKW

Pointon Way, Hampton Lovett
Droitwich Spa, WR9 0LR

www.akw-ltd.co.uk
orders.akw-ltd.co.uk



VI 11/16

**CONSTRUCTION
& ENGINEERING AWARDS 2016**
AKW
Best Accessible Bathroom & Kitchen Product Manufacturer - UK

BUILD